

AR 75^eT

Operation weight:
6,000 kg

Power:
54 kW (73 HP)

Shovel capacity:
1.0 m³



AR 75^eT

SMALL e. BIG EFFECT.

weycor wheel loaders are more than the sum of their parts. They reflect true passion, a fascination with technology and 'Made in Germany' quality.

It's thanks to the innovative spirit of our people, their dedication to detail and their passion for powerful engine technology that this new **e-generation of wheel loaders** has been developed.

The small 'e' stands for

- emission reduction: Keeps the required NOx and PM limits in accordance with the most stringent emission regulations
- efficient: higher power, lower consumption
- evolutionary: advanced designs that are optimised down to the smallest detail



WEYCOR: POWERFUL, PRECISE, RELIABLE.



LATEST KINEMATICS TECHNOLOGY

The proven and tested weycor kinematics with its exceptional tear-out force and excellent lifting heights. Telescopic cylinder with end-position cushioning.



EASY MAINTENANCE

Low-maintenance and quick, easy servicing is achieved by central, consolidated, easy-to-reach service points.



HYDRAULIC QUICK-CHANGE ATTACHMENT

By allowing you to change the wheel loader's attachments in a few seconds, it turns the vehicle into an all-rounder.



ARTICULATED PENDULUM JOINT

The combination of pendulum joint and the rear oscillating axle provides for excellent maneuverability and cross-country mobility. Even on challenging terrain, the low center of gravity ensures exceptional stability.



SEPARATE INCHING PEDAL

Less wear & tear and fuel consumption: In contrast to the conventional combined brake/inching pedal, with the separate inching pedal, the risk of inadvertently activating the main brake while you drive is eliminated.



NEGATIVE BRAKE

Serves to maintain a stable position while the wheel loader is driven on slopes with the brake or inching function activated. All four wheels are automatically blocked as soon as the engine is stopped.

COMFORTABLE CABIN

In addition to the excellent circumferential visibility in the wheel loader, its clearly arranged controls and its ergonomic design.

POWERFUL DRIVE UNIT

weycor wheel loaders are equipped with state-of-the-art engines which combine high power reserves for challenging operations with up-to-date low emission values.



DEUTZ ENGINE TECHNOLOGY

TD 2.9 L4 (DPF optional)

Newly-designed, water-cooled 4-cylinder inline engine with cooled, external exhaust gas recirculation with and without turbocharging and optionally with and without charge air cooling. Use of DVERT® oxidation catalyst (DOC) enables maintenance-free operation under all application and ambient conditions. The powerful Common Rail injection system and highly-efficient combustion process with cooled external exhaust gas recirculation ensure optimum engine performance at low fuel consumption and exhaust emissions. Best cold starting performance even under extreme conditions.

AR 75^eT

TECHNICAL DATA

ENGINE

Make	TD 2.9 L4
Type	water cooled
Power***	set to 54 kW (73 HP) at 2,200 min ⁻¹
Max. torque	260 Nm at 1,800 min ⁻¹
Stroke	2,920 cm ³
Cylinders	4 in line

Common Rail injection system with cooled external exhaust gas recirculation and oxidation catalyst. No regeneration necessary. DPF optionally available.

ELECTRICAL SYSTEM

Operating voltage	12 V
Battery	12 V / 100 Ah
Alternator	14 V / 95 A
Starter	12 V / 2.6 kW

DRIVE

- Output-regulated hydrostatic drive with pressure cut off and closed circuit acting on all 4 wheels
- Speed with standard tires:
Operating speed range 0-6.5 km/h
Road speed range 0-20 km/h
Optional high speed 40 km/h (upon request)
- 1st and 2nd hydraulic gear can be engaged under load, forward/backward travel also
- Forward/backward travel, speed ranges and off-position operational via weycor joystick
- Drive operated by accelerator and separate inching pedal for best distribution of the hydraulic power for thrust and lifting forces

BRAKES

Standard brake: Multi-disc brake in oil bath acting on all 4 wheels. Supplementary brake functions via inching pedal and hydrostatic drive acting on all 4 wheels.

Parking brake: Parking brake as spring-loaded brake acting on all 4 wheels. In case of standstill of engine the spring-loaded brake is automatically re-activated.

AXLES

Rigid axle front, pendulum rear axle with planetary reduction gears in wheel hubs, electrically connected 100%-differential lock in front and rear axle.

STEERING

- Fully hydraulic center pivot steering and oscillating rear axle
- Front and rear wheels follow the same track
- Steering angle of 40° to each side, ±10° angular movement at rear of vehicle
- Operating pressure of steering hydraulics 175 bar
- Emergency steering function

TIRES

Standard: 16/70 R20 MPT 14 PR – Multi-purpose tires for earth moving machines, with good traction, self-cleaning and firm stability

Special tires upon request

HYDRAULIC SYSTEM

- Gear pump for loading and steering hydraulics
- Priority valve favoring steering hydraulics
- Lowering brake dependent of load
- 4th hydraulic section
- Loading hydraulic hydraulically pre-activate via weycor joystick, including float position
- Operating pressure 230 bar, Delivery of pump 62 l/min

LOADING EQUIPMENT

- Powerful and solid Z-kinematics with high tear out force
- Telescopic range 1,200 mm
- Telescopic cylinder with damping working cylinder
- Hydraulic quick change device
- Activation of all functions via weycor joystick
- Parallel movement while using pallet forks
- Locking device acc. to German StVZO for road travel
- **Lifting 6.5 s**
- **Lowering 6.0 s**
- **Tipping 1.8 s**

FUEL/OIL CAPACITIES

Diesel	80 Liter
Hydraulic oil	75 Liter
Engine oil	13 Liter
Front axle	4.5 Liter
Rear axle	4.2 Liter
Gear oil	2.5 Liter
Cooling liquid	15 Liter

STANDARD EQUIPMENT

INCLUSIVE

- Rear driving mirrors, foldable
- Heatable rear screen
- Comfortable access to cab from both sides
- Joystick with integrated proportional steering including telescoping function
- weycor diagnostic system
- Control lights for speed range, forward/backward travel
- Lights acc. to German StVZO for road travel
- Individually adjustable driver's seat with adjustable right arm rest
- Engine oil heating with heat exchange and 4-stage fan
- Front windscreen ventilation, variable output
- Sound absorbing ROPS cab
- Windscreen wipe and wash unit in front and rear
- Sun visor, coat hook, ceiling lamp, stow facility
- Adjustable steering column
- Heat protection glazing with targetinted screens
- Control lights for engine oil pressure, overheating, hydraulic oil temperature, battery power, parking brake and air filter
- Central dashboard with indicators for preheating, engine temperature, fuel, working hour meter
- Cyclone dust separator with air filter control

OPTIONS

TECHNICAL OPTIONS

- Stability damping system
- High speed version 40 km/h
- Air conditioning
- Hand throttle unit
- Load check valve
- Main battery switch
- Corrosion prevention against salt
- Special paintings and oils
- Trailer coupling
- Heatable and air cushioned seats
- Auxiliary heating, comfort cab
- Radio
- Warning beacon
- Doors with sliding windows, left and right side
- Anti-theft-device with code stick
- Glass roof arrangeable
- Hydraulic start-stop system
- Diesel particulate filter

More options upon request

TECHNICAL DATA AR 75e T WITH STANDARD SHOVEL

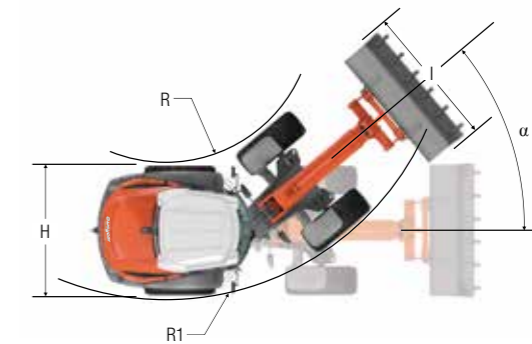
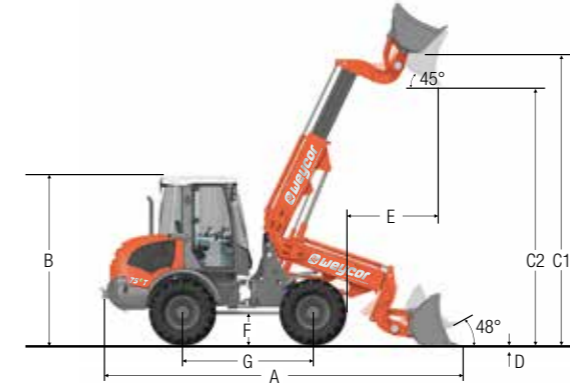

A	5,804 mm
B	2,796 mm
C1	4,838 mm
C2	4,080 mm
D	60 mm
E	1,380 mm
F	492 mm
G	2,200 mm
H	1,950 mm
I	2,150 mm
R	2,105 mm
R1	4,545 mm
α	40°

TECHNICAL DATA AR 75e T WITH PALLET FORKS

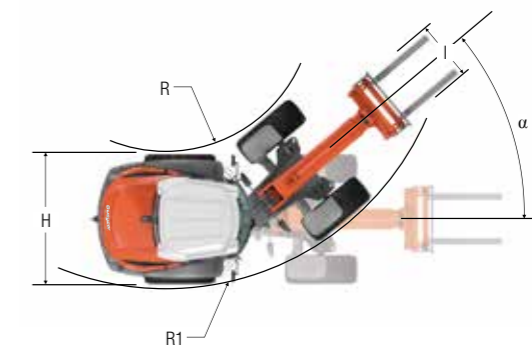
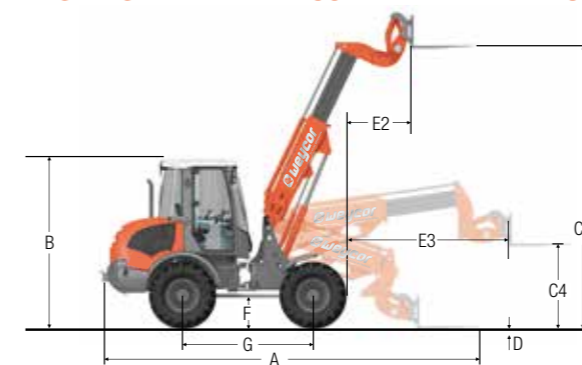

A1	6,124 mm
B	2,796 mm
C4	1,530 mm
C5	4,650 mm
D	60 mm
E2	1,074 mm
E3	2,695 mm
F	492 mm
G	2,200 mm
H	1,950 mm
I	1,030 mm
R	2,105 mm
R1	4,545 mm
α	40°

DIAGRAM FOR SHOVEL SELECTION

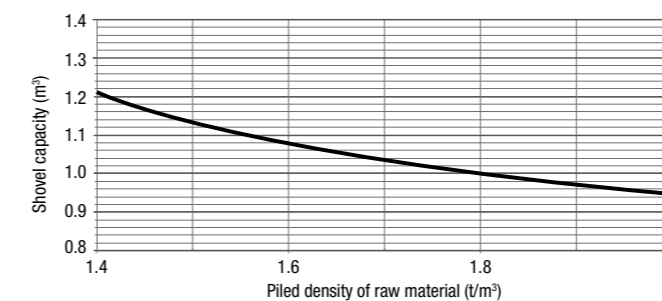

SPECIFIC GRAVITY FOR MATERIAL HANDLING WEIGHT (t/m³)

Construction	Industry	
concrete	ember	phosphate fertiliser
soil (dry)	brown coal briquette	turf (watery)
soil (watery)	ferrous product	turf (dry)
rock (fill)	iron ore	mineral fertiliser
granite	cullet	
limestone	gas coke	
gravel (dry)	timber	
gravel (watery)	mineral coal	
loam	paper	
plaster	slag	
sand (dry)	slag concrete	
sand (watery)		
sandstone		
shale		
sediment		
crushed stone		
de-icing salt		
clay		
cement		
clinker (stacked)		
	Landscaping, Agriculture	
	agricultural crop	
	grain	
	hay	
	potash	
	compost	
	flour	
	clay (watery)	

OPERATING DATA

Shovel capacity acc. to SAE	1.0 m ³ (5)
Track width	1,520 mm
Tear out force	4,300 daN
Torque	4,310 daN
Tipping load, straight	3,500 kg
Tipping load, straight / extended	1,970 kg
Tipping load, articulated	3,150 kg
Tipping load, articulated / extended	1,760 kg
Lifting capacity at ground level	3,600 daN
Service weight	6,000 kg

Differing data for use of pallet forks
(500 mm distance to center of gravity)*

Static tipping load, articulated	2,680 kg
Static tipping load, articulated / extended	1,590 kg
Lifting capacity	2,710 daN
Payload 80% even surface**	2,144 kg
Payload 80% extended boom**	1,272 kg
Payload 60% uneven surface***	1,608 kg
Payload 60% extended boom***	954 kg

Sound level Agrar- / Cabin-version

Average acoustic power-level L_{WA}(1)	100.0 dB(A)
Guaranteed acoustic power-level L_{WA}(2)	101.0 dB(A)
Sound pressure level L_{pA}(3)	77.0 dB(A)
Specific vibration-data Hand- / arm- / bodyvibration(4)	< 2.5/0.5 m/s ²

* Travel with load only permitted close to the ground.
** According to ISO 8313 and EN 474-3. *** According to ISO 14396, EU RL97/68/EC. (1) According to 2000/14/EG & appendixes.
(2) According to 2000/14/EG & appendixes. (3) According to ISO 6396.
(4) According to ISO 8041. (5) If you participate in public traffic gem. StVZO only the loading shovel with the number 8059493 is allowed.

PRODUCT RANGE

S

AR 30

Operation weight	2,150 kg
Power	24.6 kW (33.5 HP)
Shovel capacity	0.32 - 0.45 m ³

AR 35

Operation weight	2,500 kg
Power	24.6 kW (33.5 HP)
Shovel capacity	0.34 - 0.45 m ³

AR 35 Super

Operation weight	2,875 kg
Power	29.4 kW (40.0 HP)
Shovel capacity	0.34 - 0.50 m ³

AR 40

Operation weight	3,500 kg
Power	29.4 kW (40.0 HP)
Shovel capacity	0.50 - 0.60 m ³

Operation weight

Power

Shovel capacity

Model range L



AR 60

4,300 kg / 4,650 kg
36.5 kW (50.0 HP)
0.65 - 1.00 m ³



AR 65^e

5,150 kg
54.0 kW (73.0 HP)
0.80 - 1.05 m ³



AR 75^e

5,760 kg
54.0 kW (73.0 HP)
1.00 - 1.25 m ³



AR 75^e S

6,280 kg
54.0 kW (73.0 HP)
0.80 m ³



AR 75^e T

6,000 kg
54.0 kW (73.0 HP)
1.00 m ³

XL

AR 80^e

6,220 kg
70.0 kW (95.0 HP)
1.10 - 1.30 m ³

AR 85^e

7,000 kg
80.0 kW (109.0 HP)
1.30 - 1.50 m ³

AR 95^e

7,900 kg
85.0 kW (115.5 HP)
1.40 - 2.00 m ³

AR 95^e Super

8,200 kg
95.0 kW (129.0 HP)
1.40 - 2.00 m ³

XXL

AR 105^e

9,450 kg
105.0 kW (143.0 HP)
1.60 - 2.00 m ³

AR 200^e

12,400 kg
115.0 kW (156.0 HP)
2.10 - 2.50 m ³

AR 250^e

13,800 kg
160.0 kW (218.0 HP)
2.40 - 3.00 m ³

Compliance with the new statutory limits for exhaust emissions is one thing. Deriving tangible benefits for our customers is another. We are proud to have incorporated both in the development of the new generation of wheel loaders.

Higher power - lower consumption plus a series of other innovative features that make a genuinely positive difference in a construction site environment. All the features inside are now represented on the outside by a small 'e' and the new product name 'weycor'.

weycor is an ATLAS WEYHAUSEN GMBH brand.

ATLAS WEYHAUSEN GMBH · D - 27793 Wildeshausen
Phone +49 (0) 44 31 - 98 10 · info@weycor.de · www.weycor.de

 **weycor**
BY ATLAS WEYHAUSEN

Under our policy of continuous improvement, we reserve the right to change specifications and design without prior notice, errors expected. The technical data refer only to the standard version, illustrations do not necessarily show the standard version of the machine. Not all products are available in all markets.